

LEGACY Drawer System

Specifications & Ordering Guide

Internal Drawer Kit, 172mm C Height with Glass & Cross Rail Product Features



- Modern Straight Slim box drawer system
- Silent system guarantees quiet, smooth run
- High dynamic load capacity: 40/60kg (88/132lbs)
- Concealed slide with full extension
- Tool free assembly and removal of drawer
- 3D Adjustment

Glass Sides Drawer Kit (packaged as a complete set)

Order Glass Sides Drawer Kit with 172mm C Height Sides, plus these parts

- One pair of internal front fixing brackets for use with standard height internal drawer fronts and square cross rail
- One standard height colour-matched 1100mm length metal internal drawer front, which can be cut to match your drawer width
- One square cross rail, which can be cut to match the width of your drawer

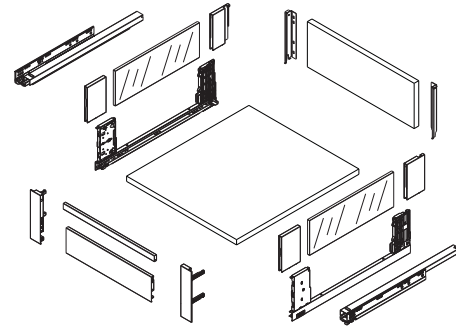

High Internal Drawer Front Brackets for Square Cross Rail

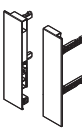
	Finish	Part#	Qty.
	Matte Grey	105-HT13014-GM	60
	Silk White	105-HT13014-SW	60

Standard Height, Internal Drawer Front, 1100mm Lengths

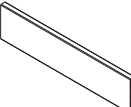
	Finish	Part#	Qty.
	Matte Grey	105-HT10022-GM	60
	Silk White	105-HT10022-SW	60

Internal Drawer Square Cross Rail, 1100mm Lengths

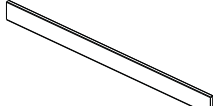
	Finish	Part#	Qty.
	Matte Grey	105-HT10071-GM	60
	Silk White	105-HT10071-SW	60

LEGACY Drawer System

Specifications & Ordering Guide

Space Requirements

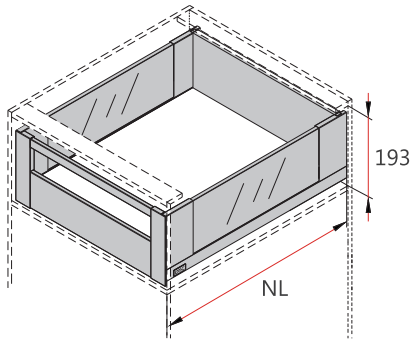

Installation Dimensions

NL=Nominal Slide Length
 LT=Internal Cabinet Depth
 LT=NL+3

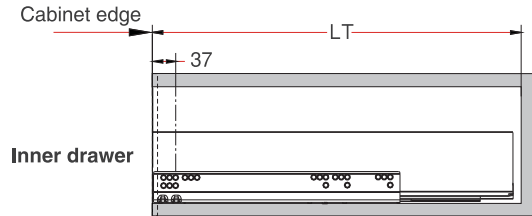

Installation Dimensions

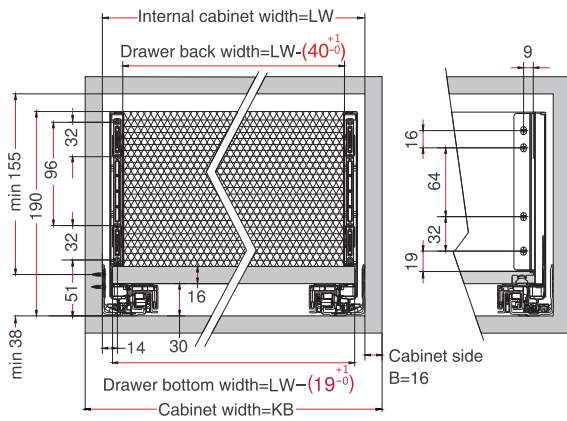

Drilling Pattern

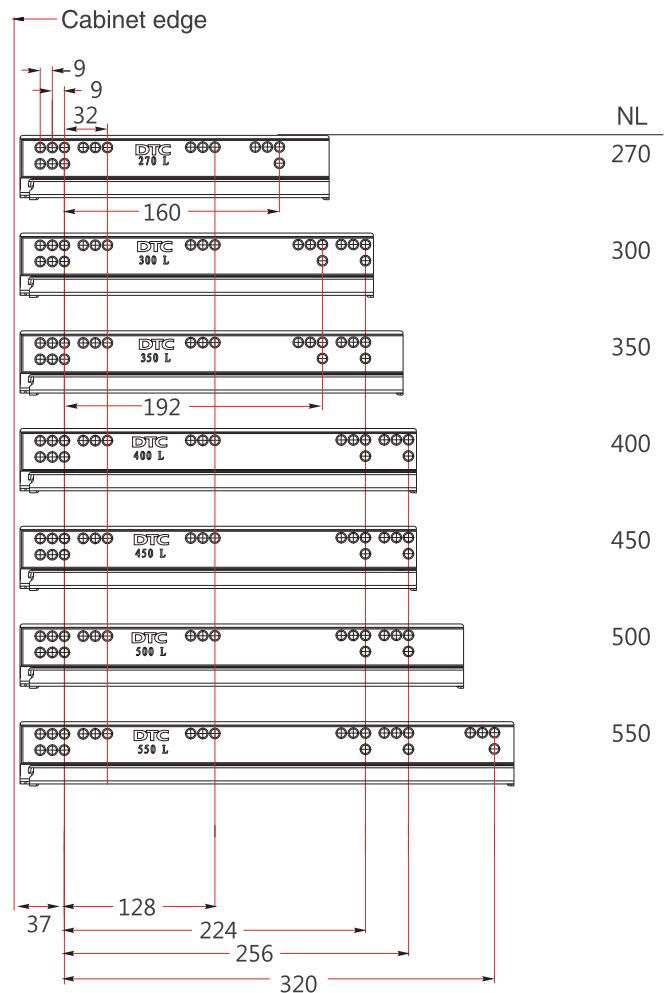

Drawer Front, Back and Bottom Dimension

